

RAM  
**PROMASTER CITY**



**UPFIT**  
GUIDE



# Helping Mobile Technicians Work More Effectively by Providing Organized Storage Solutions

## At Ranger Design, we believe more is possible.

We believe work vehicles and the technicians that drive them can become more organized, more efficient, more productive and more profitable. At Ranger Design we're committed to bringing you the products and services that make that possible.

More means helping you choose the right work van for your

application, as well as giving you engineering support and expert advice to help design the most efficient work space in your new vehicle.

More also means getting that new van outfitted and on the road faster, so you can start using it for the reason you bought it.

We're committed to bringing you more, because we believe more is possible.



**MORE IS POSSIBLE**



## TABLE OF CONTENTS

CHOOSE A PRODUCT LINE . . . . .	P. 4
PLAN YOUR VAN OUTFIT . . . . .	P. 6
FLOORS . . . . .	P. 8
PARTITIONS . . . . .	P. 10
PACKAGES . . . . .	P. 14
SHELVING . . . . .	P. 36
DRAWERS . . . . .	P. 41
ACCESSORIES . . . . .	P. 50
LADDER RACKS . . . . .	P. 61
INSTALL KITS . . . . .	P. 63
HOW TO BUY . . . . .	P. 64
INDEX . . . . .	P. 66

# Choose A Product Line To Match Your Needs

Ranger Fleetline and Proline product groups ensure that fleets of any size have the best equipment to fit their budget, trade or fuel saving targets.



Ranger Fleetline shown



Ranger Proline shown

	<b>MATERIAL</b>	<b>BENEFITS</b>	<b>PRODUCTS</b>	<b>WARRANTY</b>
<p><b>WHY BUY RANGER FLEETLINE?</b> You want better quality and price than other steel products on the market.</p>	Steel	Tough Low cost Quiet	Shelving, Partitions, Drawers, Accessories	3 years*
<p><b>WHY BUY RANGER PROLINE?</b> You want the toughest, quietest product on the market. You need to optimize payload without sacrificing quality.</p>	Aluminum	<b>Toughest</b> <b>Lightweight</b> Quiet	<b>Shelving, Partitions,</b> <b>Drawers, Accessories,</b> <b>Ladder Racks</b>	<b>10 years*</b>

\*Ranger Design Inc. van equipment is warranted to be free from defects in material and workmanship under normal use and service for the period indicated, from the date of the original retail purchase, when installed per Ranger Design instructions in the original vehicle. Please contact Customer Service for full warranty details. Email: [cs@rangerdesign.com](mailto:cs@rangerdesign.com)

Throughout the catalog **FLEETLINE** products are depicted with yellow and **PROLINE** products with black.

**1-800-565-5321**  
7 A.M. – 8 P.M. EST

# World Class Customer Service



## Real people, ready to answer in 2 rings or less\*

We are pleased to offer efficient, personalized service and to answer all questions regarding:

- › Pricing/Quoting
- › Product install
- › Order status
- › Consultation
- › Shipment status
- › New product availability
- › Product specifications
- › Warranty claims
- › Returns/Restocking
- › Vehicle specifications

\*Call customer service and the phone will be answered in 2 rings or less. Yes, a real, live person working in one of our offices in North America is available to answer your questions. No automated attendant. No complicated phone tree and offshore service. Call us to experience the difference.

# PLAN YOUR VAN OUTFIT

## INSIDE ROOF HEIGHT

To determine the maximum shelf height that can be used in the van.

## PARTITION DEPTH

This indicates the space taken up by our partition for this vehicle. Please note that this measurement is determined by the partition that encroaches the most. Some partitions may take up less space. Take note that this measurement may not necessarily be on the floor.

## DOOR OPENING

To determine where shelving will land in relation to the door opening. Use this measurement to determine the space available for drawer units.

## FLOOR SPACE

This area is usable floor space but due to curvature of the van there may not be the same available area at the roof. Please measure actual van for specific measurement at roof.

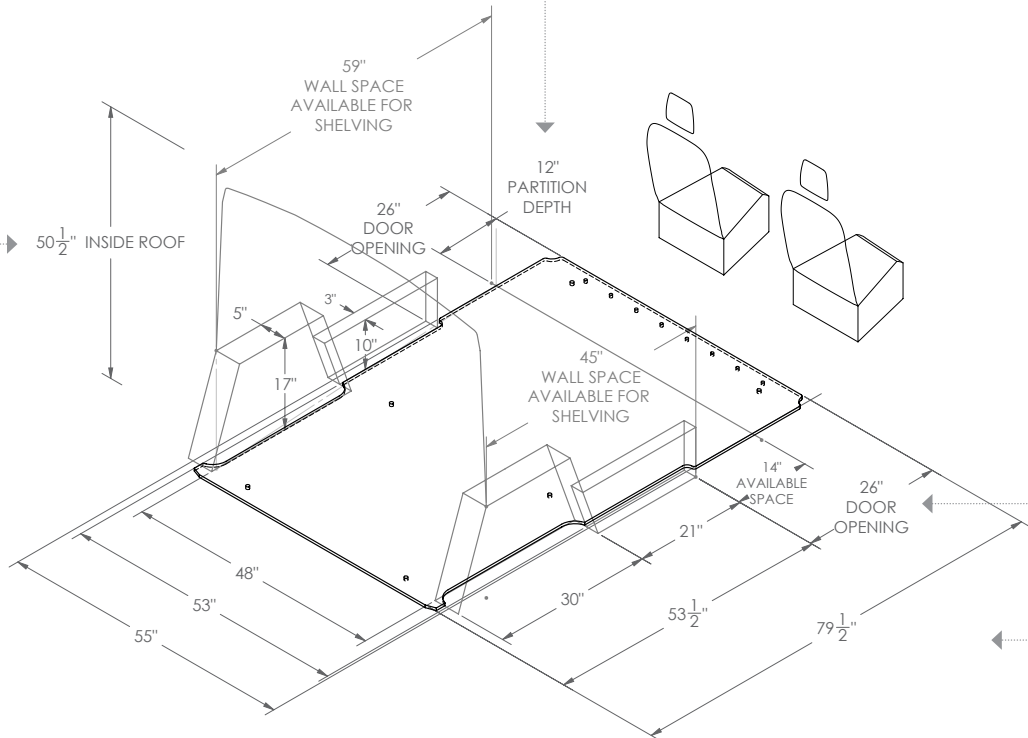

**RAM**  
**PROMASTER CITY**  
Standard 122" Wheelbase



# Storage zones

---

---

---

---

---

---

---

---

---

---

---

---

---

---

---

---

---

---

---

---

---

---

---

---

---

---

---

---

---

---

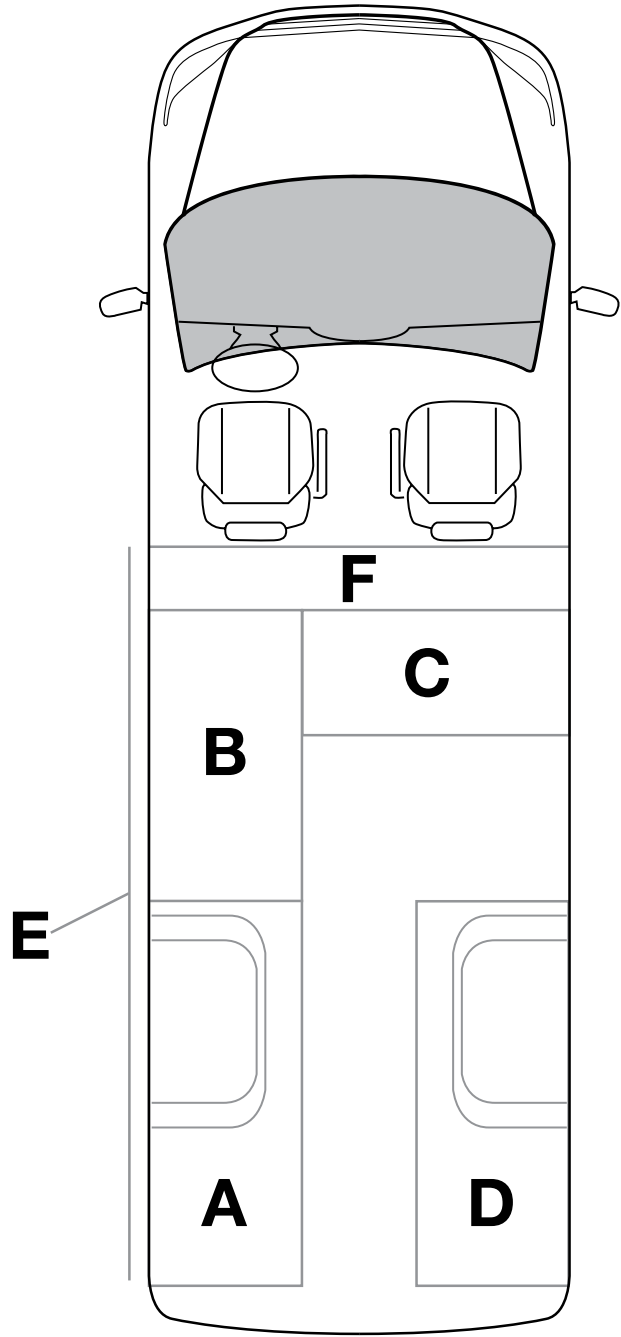

Regular

- A** - Driver Side Rear
- B** - Driver Side Front
- C** - Partition and Slide Door
- D** - Passenger Side
- E** - Roof
- F** - Partition

# IT'S MORE THAN A FLOOR

Ranger Design's unique flooring system with integrated aluminum mounting tracks provide a flush surface, making it easy to install a variety of Ranger Design shelving, equipment and accessories.

Ranger Designs' custom-fit rigid flooring system is available for every type of service van. Designed to provide added safety and quieter ride, these impact and puncture-resistant floors give your van a professional look.

Unique benefits of these flooring products include:

- **Economical** – because the flooring has integrated mounting tracks for the price of a regular floor
- **Safer** – due to the integrated track, improved load distribution and noise reduction
- **Improved van resale value** – durable professional looking and protects the vehicle
- **Efficient** – 3 panel floor installed in 45 minutes by one person and easy to maintain



## PROTECTION

The floor protects your vehicle and prevents damage to the factory floor.



## SAFETY

Due to the integrated track, improved load distribution and noise reduction.

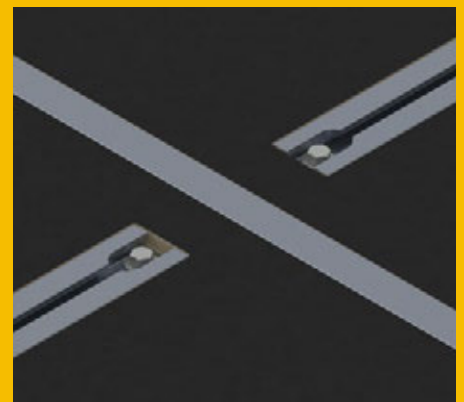

## EFFICIENCY



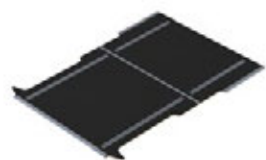

Custom-fit easy to install by one person.





## 6540-PC

ProMaster City Floor

	122"
	46 lbs
	1 hr
	Yes

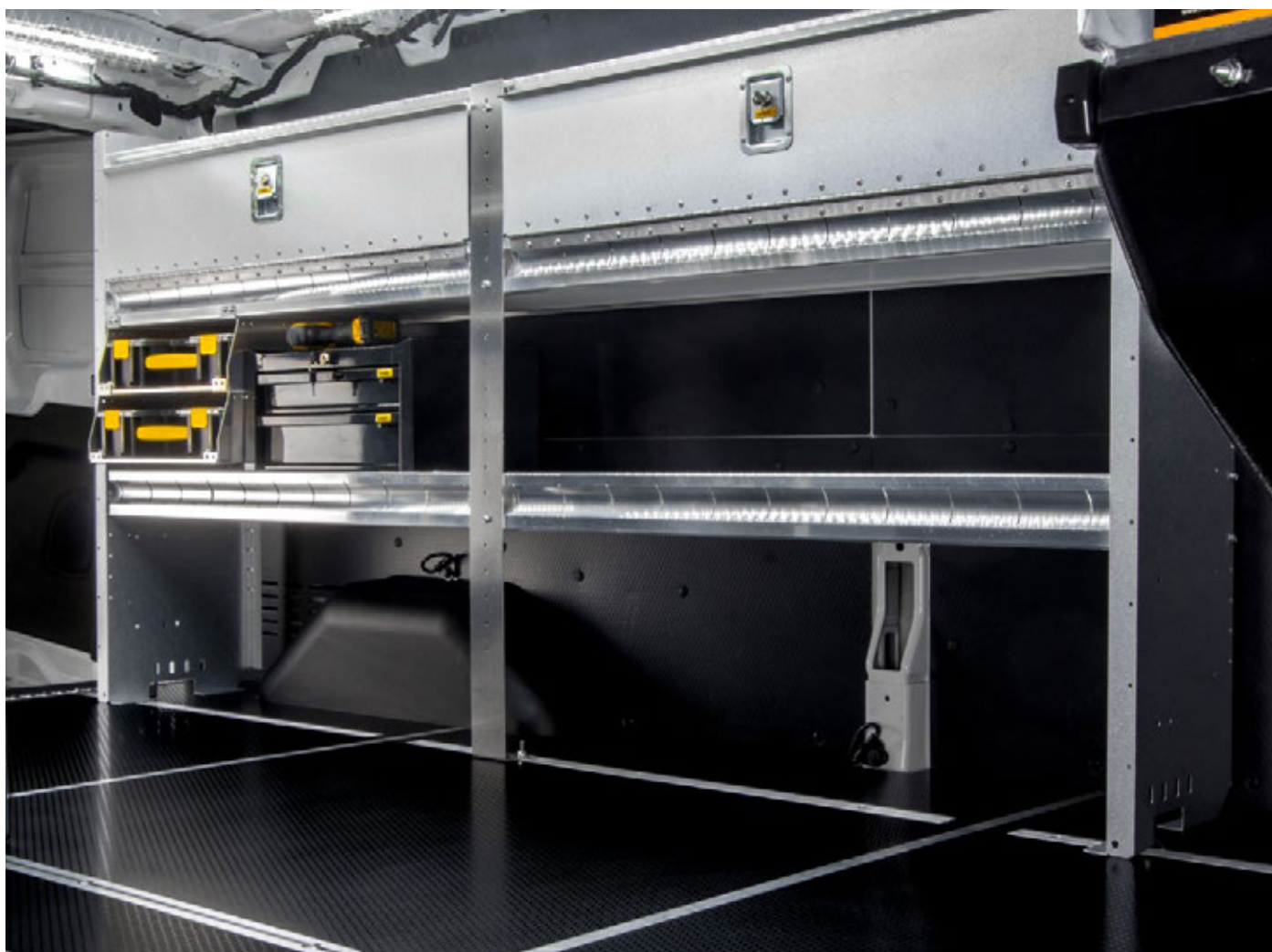
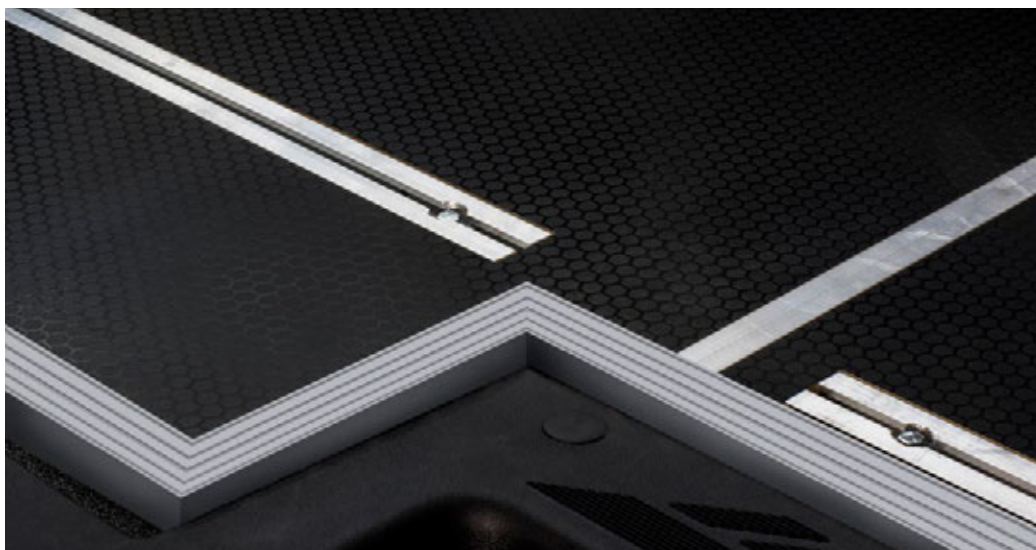

Impact and puncture resistant floors preserve the cargo van interior.



## **SAFETY PARTITIONS**

Crash tested safety partitions protect the most important asset: you



**SAFE**

Designed for maximum impact resistance.  
Proven by impact testing.

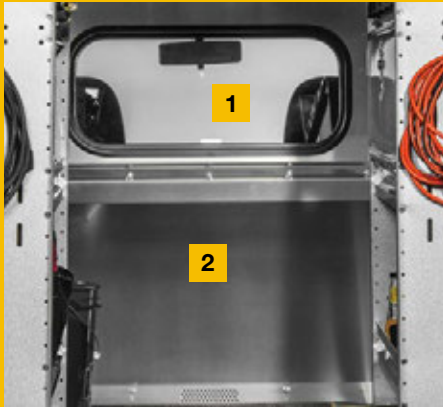

**EFFICIENT**

1. Contoured to maintain seat travel and ensure driver comfort. 2. Contoured to capitalize on cargo area floor space.

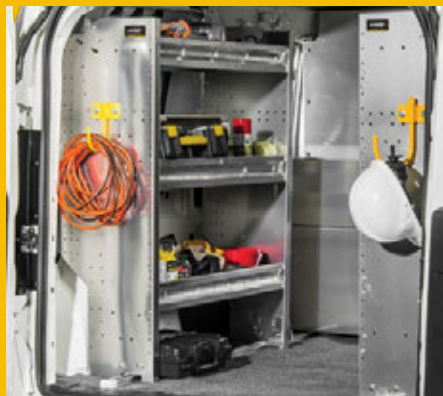

**QUIET**

Thickness of material cancels vibrations.

# SAFETY PARTITIONS

CONTOURED SAFETY PARTITION . . . . . P. 12

CONTOURED SAFETY PARTITION WITH PERFORATED WINDOW . . . . . P. 13

CONTOURED SAFETY PARTITION WITH TEMPERED WINDOW . . . . . P. 12

MAX VIEW PARTITION . . . . . P. 12

WIRE MESH PARTITION . . . . . P. 13

Ranger safety partitions provide a solid and secure barrier between the occupants of the van and the cargo.

Built from heavy gauge steel, aluminum and thermoformed ABS and polycarbonate, they are designed for maximum impact resistance and uphold a standard of safety set only by Ranger products.

Ranger partitions also provide a more comfortable environment for the driver by giving more seat travel and by not rattling as the vehicle drives down the road.



## MAX VIEW SAFETY PARTITION



WINNER OF

THE  
WORK  
TRUCK  
SHOW

2016  
INNOVATION  
AWARD

Max View Safety Partitions are built from thermoformed ABS and polycarbonate and are engineered to resist maximum impact. With a snug fit and rattle free construction they give you:

- > Maximized seat travel
- > 180 degree rear visibility
- > Improved climate control

### 3320-PC

Max View Contoured Safety Partition

#### Composite

- 42 lbs
- 1 hr
- No



### 3320-PC

Max View Contoured Safety Partition

#### Composite

- Standard Roof
- 42 lbs
- 1 hr
- No
- 7.1



### 3310-PC

Contoured Safety Partition

#### Composite

- Standard Roof
- 44 lbs
- 1 hr
- No
- 7.1"



### 3010-PC

Contoured Safety Partition

#### Aluminum

- Standard Roof
- 39 lbs
- 1 hr
- Yes
- 8.1"



### 3020-PC

Contoured Safety Partition with Tempered Glass Window

Aluminum	
Standard Roof	
41 lbs	
1 hr	
Yes	
8.1"	



### C10-PC

Contoured Safety Partition with Perforated Window

Steel	
Standard Roof	
85 lbs	
1 hr	
Yes	
8.05"	



### C12-PC

Contoured Safety Partition

Steel	
Standard Roof	
86 lbs	
1 hr	
Yes	
8.05"	



### C13-PC

Wire Mesh Partition

Steel	
Standard Roof	
72 lbs	
1 hr	
Yes	
8.33"	

## SETBACK FROM B PILLAR

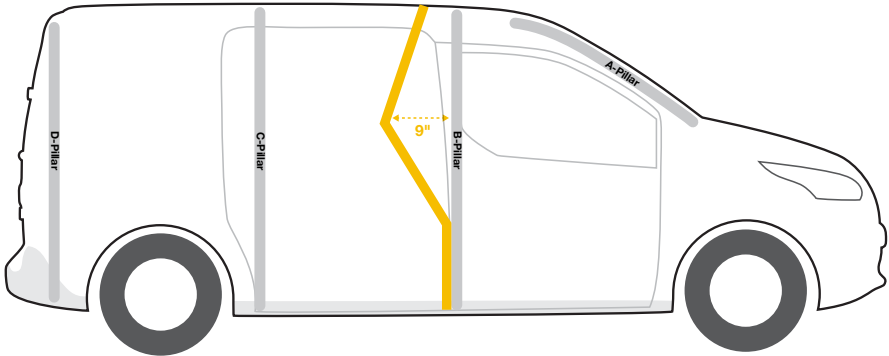



# TRADE PACKAGES

Pre-engineered packages for a broad range of trades.



### CHOICE

A range of Fleetline and Proline packages are available for each vehicle.



### TRADE SPECIFIC

Packages are created with the specific trades in mind. Optimized for maximum productivity.



### PERFECT FIT

Engineered to optimize space. Layout designed to ensure that all tools are well within reach.

## TRADE PACKAGES

CONTRACTOR . . . . .	P. 16
DELIVERY . . . . .	P. 32
ELECTRICAL . . . . .	P. 20
HVAC . . . . .	P. 24
SERVICE . . . . .	P. 28

Get more out of your work van: Ranger packages are designed specifically with your trade in mind. Our aim is to ensure that your most frequently used tools and equipment are well within reach.

Do you see a way that we can improve our packages? We appreciate your feedback! Contact our customer service team at **1-800-565-5321**.







# Z10-H3

## Contractor

### **TOUGH**

Extrusion builds durability into shelf.

### **QUIET**

The combination of the extrusion, shelf tray, and end-panels create durable, vibration-free shelves.

### **EFFICIENT**

Ergonomic design reduces injuries and increases productivity.



\*Preproduction model shown,  
do not use as an installation guide.

## Z10-H3

Steel

Base Contractor Package

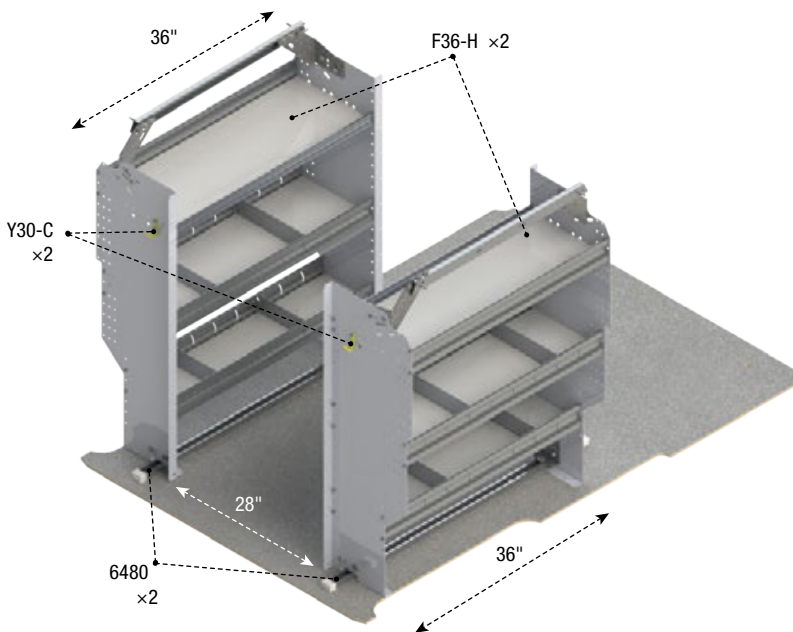

PACKAGES



### Z10-H3

122"

Standard

98 lbs

2.4 hrs

Yes

Qty	Part #	Description
2	6480	Shelving install kit
2	F36-H	Contoured Shelving Unit with Dividers
2	Y30-C	Coat Hook, 1" opening, chrome plated

ADD YOUR  
**ACCESSORIES**  
P.50



PICK YOUR  
**PARTITION**  
P.10



CHOOSE YOUR  
**LADDER RACK**  
P.61



# Z10-H4

**Steel**

Deluxe Contractor Package

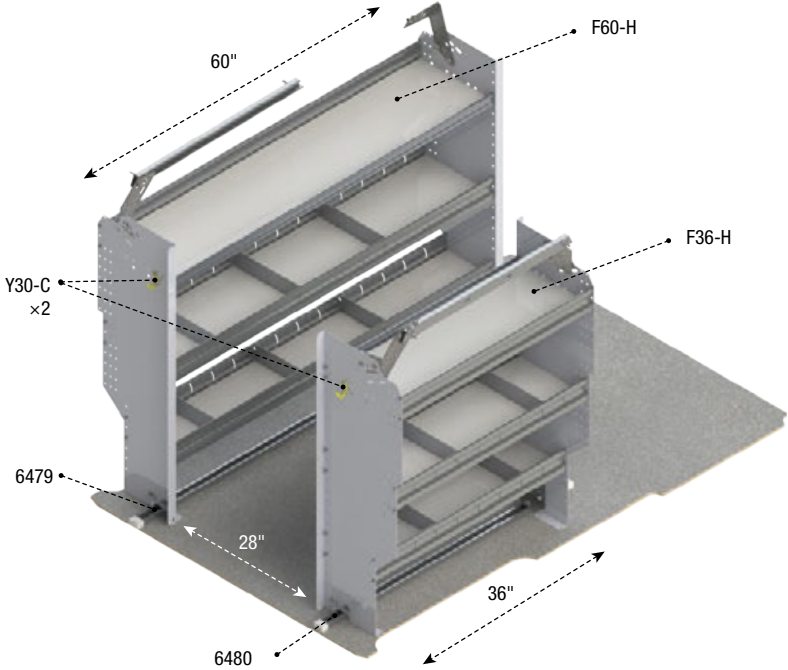

PACKAGES



## Z10-H4

122"	Standard	110 lbs
2.4 hrs	Yes	

Qty	Part #	Description
1	6479	Shelving install kit
1	6480	Shelving install kit
1	F36-H	Contoured Shelving Unit with Dividers
1	F60-H	Contoured Shelving Unit with Dividers
2	Y30-C	Coat Hook, 1" opening, chrome plated

## GET MORE OUT OF YOUR WORK VAN

Ranger Design packages are designed specifically with your trade in mind. Our aim is to ensure that your most frequently used tools and equipment are well within reach. Do you see a way that we can improve our packages? We appreciate your feedback! Contact our customer service team at 1-800-565-5321.

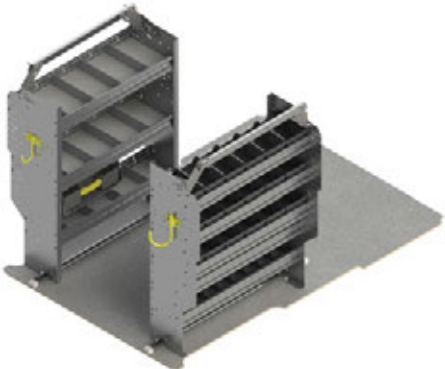



# H411

## Electrical

### **TOUGH**

Extrusion builds durability into shelf.

### **QUIET**

The combination of the extrusion, shelf tray, and end-panels create durable, vibration-free shelves.

### **EFFICIENT**

Ergonomic design reduces injuries and increases productivity.



\*Preproduction model shown,  
do not use as an installation guide.

# H311

Aluminum

Base Electrical Package

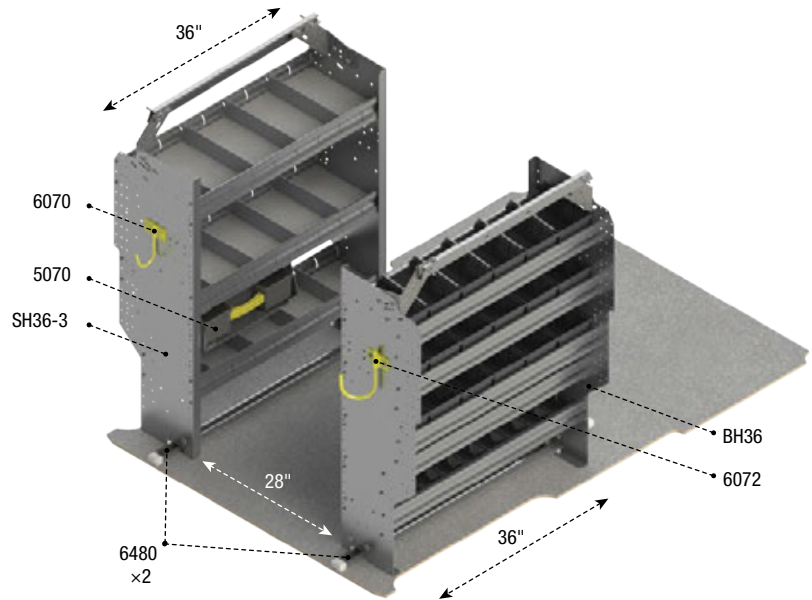

## H311

122"	Standard	129 lbs
2.7 hrs	Yes	

Qty	Part #	Description
1	5070	Partskeeper carry case with holder, universal
1	6070	6" Hook, 3" opening, painted
1	6072	8" Swivel Hook, 4" opening, painted
2	6480	Shelving install kit
1	BH36	Contoured Bin Shelving Unit
1	SH36-3	Contoured Shelving Unit with Dividers

ADD YOUR  
**ACCESSORIES**  
P.50



PICK YOUR  
**PARTITION**  
P.10



CHOOSE YOUR  
**LADDER RACK**  
P.61



# H411

Aluminum

Deluxe Electrical Package

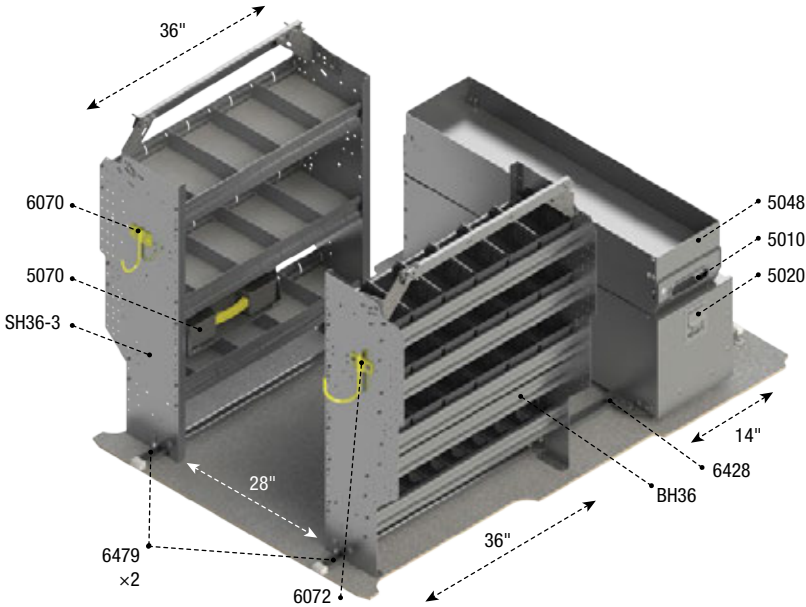

## H411

122"	Standard	210 lbs
4.4 hrs	Yes	

Qty	Part #	Description
1	5010	Partslider drawer
1	5020	Tool drawer
1	5048	Top edge, for 5010 Partslider
1	5070	Partskeeper carry case with holder, universal
1	6070	6" Hook, 3" opening, painted
1	6072	8" Swivel Hook, 4" opening, painted
1	6428	5020 Tool drawer install kit
2	6479	Shelving install kit
1	BH36	Contoured Bin Shelving Unit
1	SH36-3	Contoured Shelving Unit with Dividers

## RANGER DESIGN BINS

Ranger Design bins ensure complete organization on the jobsite or on the go.

P.50





RANGER

RANGER

Honeywell  
Genetron 22



# H412

## HVAC

### **TOUGH**

Extrusion builds durability into shelf.

### **QUIET**

The combination of the extrusion, shelf tray, and end-panels create durable, vibration-free shelves.

### **EFFICIENT**

Ergonomic design reduces injuries and increases productivity.



\*Preproduction model shown,  
do not use as an installation guide.

## H312

Aluminum

Base HVAC Package

PACKAGES

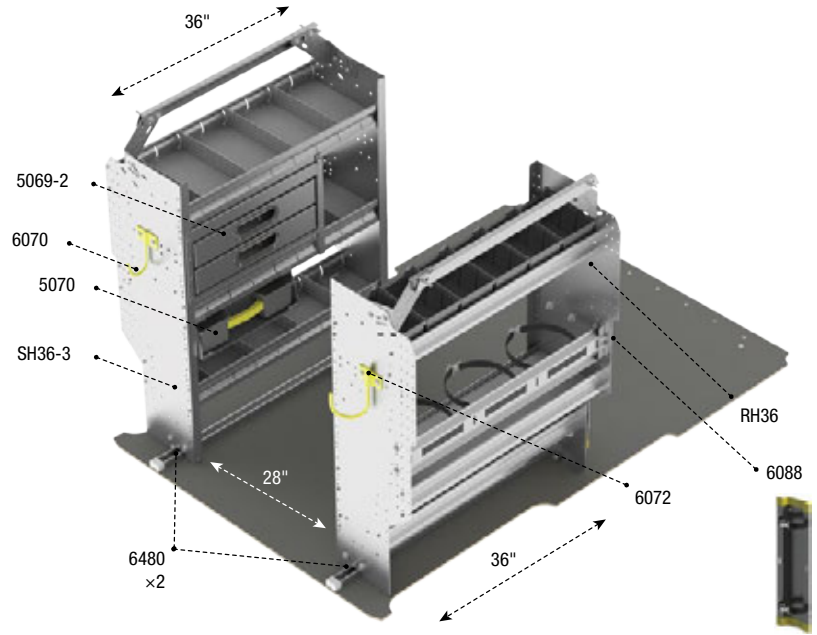

### H312

122"	Standard	144 lbs
3.4 hrs	Yes	

Qty	Part #	Description
1	5069-2	2 Drawer cabinet
1	5070	Partskeeper carry case with holder, universal
1	6070	6" Hook, 3" opening, painted
1	6072	8" Swivel Hook, 4" opening, painted
1	6088	Large aluminum bottle holder, with two black nylon straps
2	6480	Shelving install kit
1	RH36	Contoured Refrigerant Bin Unit
1	SH36-3	Contoured Shelving Unit with Dividers

ADD YOUR  
**ACCESSORIES**  
P.50



PICK YOUR  
**PARTITION**  
P.10



CHOOSE YOUR  
**LADDER RACK**  
P.61



# H412

Aluminum

Deluxe HVAC Package

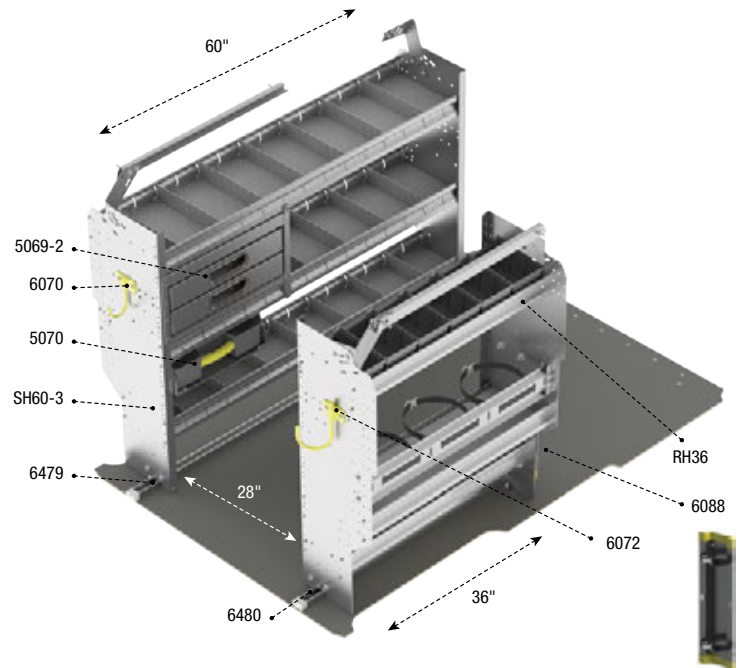

## H412

122"

Standard

161 lbs

3.4 hrs

Yes

Qty	Part #	Description
1	5069-2	2 Drawer cabinet
1	5070	Partskeeper carry case with holder, universal
1	6070	6" Hook, 3" opening, painted
1	6072	8" Swivel Hook, 4" opening, painted
1	6088	Large aluminum bottle holder, with two black nylon straps
1	6479	Shelving install kit
1	6480	Shelving install kit
1	RH36	Contoured Refrigerant Bin Unit
1	SH60-3	Contoured Shelving Unit with Dividers

## RANGER DESIGN PARTSKEEPER

The Ranger Design Partskeeper helps the mobile technician to take small parts anywhere on the job site and save return trips to the van. Removable bins included.

P.46





# Z16-H3

## Service

### **TOUGH**

Extrusion builds durability into shelf.

### **QUIET**

The combination of the extrusion, shelf tray, and end-panels create durable, vibration-free shelves.

### **EFFICIENT**

Ergonomic design reduces injuries and increases productivity.



\*Preproduction model shown,  
do not use as an installation guide.

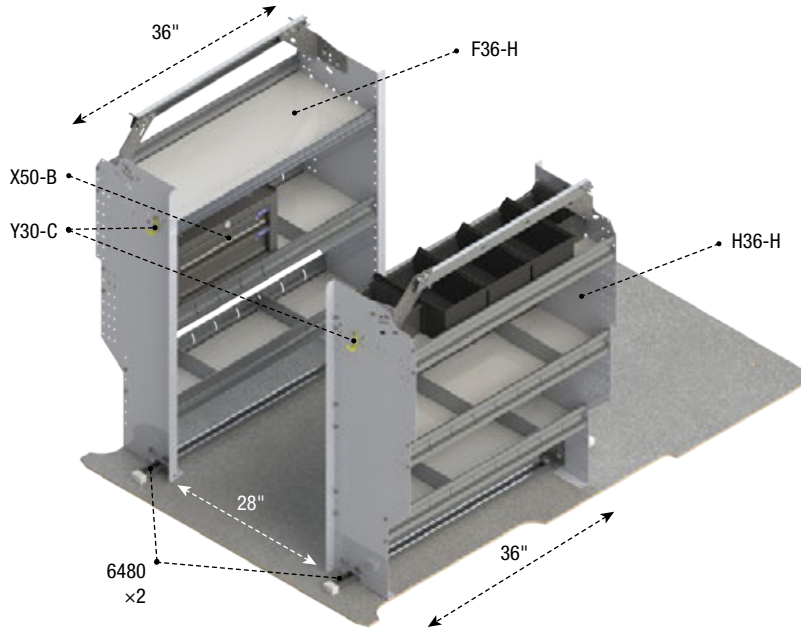

## Z16-H3

**Steel**

Base Service Package

122"

Standard

130 lbs

2.7 hrs

Yes

Qty	Part #	Description
2	6480	Shelving install kit
1	F36-H	Contoured Shelving Unit with Dividers
1	H36-H	Contoured Bin Shelving Unit
1	X50-B	Compact 2-Drawer Unit
2	Y30-C	Coat Hook, 1" opening, chrome plated

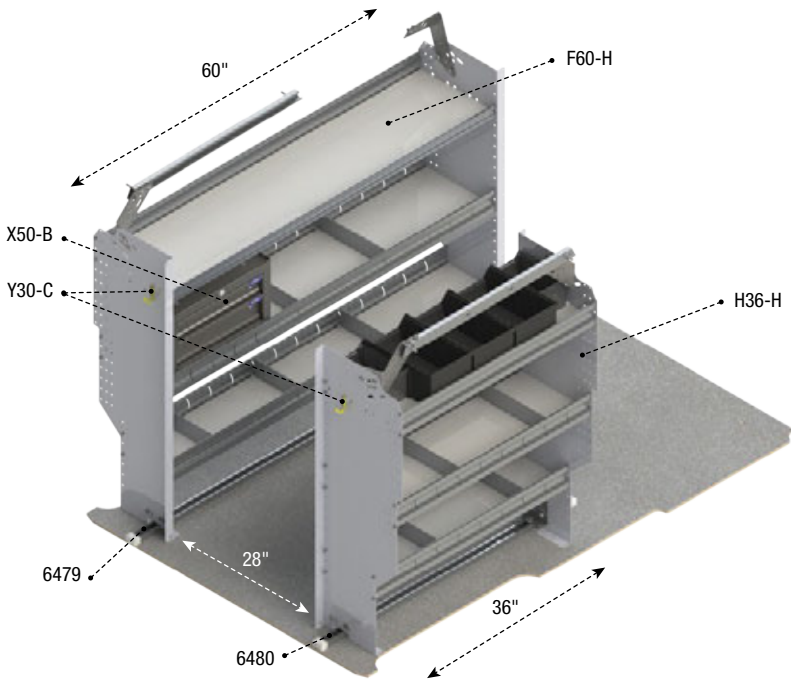

## Z16-H4

**Steel**

Deluxe Service Package

122"

Standard

142 lbs

2.7 hrs

Yes

Qty	Part #	Description
1	6479	Shelving install kit
1	6480	Shelving install kit
1	F60-H	Contoured Shelving Unit with Dividers
1	H36-H	Contoured Bin Shelving Unit
1	X50-B	Compact 2-Drawer Unit
2	Y30-C	Coat Hook, 1" opening, chrome plated

# H316

Aluminum

Base Service Package

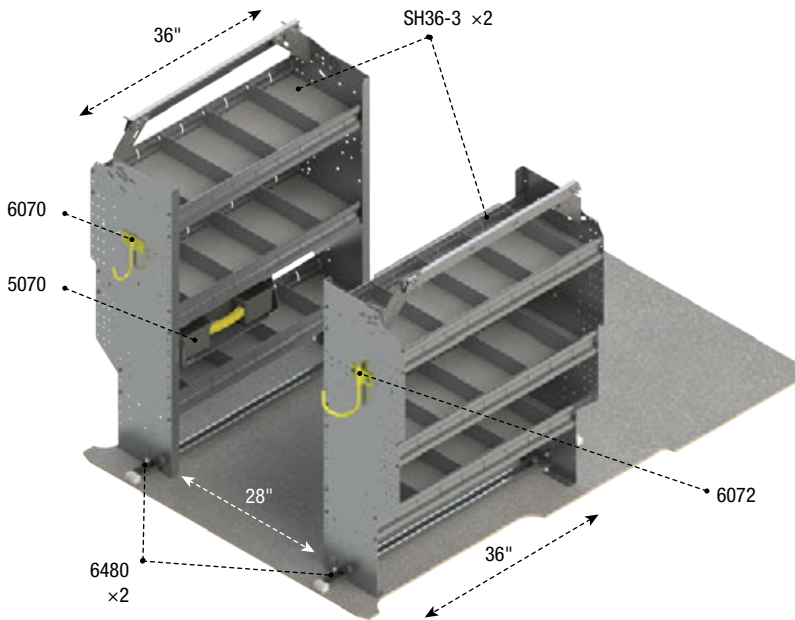

122"	Standard	106 lbs
2.7 hrs	Yes	

Qty	Part #	Description
1	5070	Partskeeper carry case with holder, universal
1	6070	6" Hook, 3" opening, painted
1	6072	8" Swivel Hook, 4" opening, painted
2	6480	Shelving install kit
2	SH36-3	Contoured Shelving Unit with Dividers

# H416

Aluminum

Deluxe Service Package

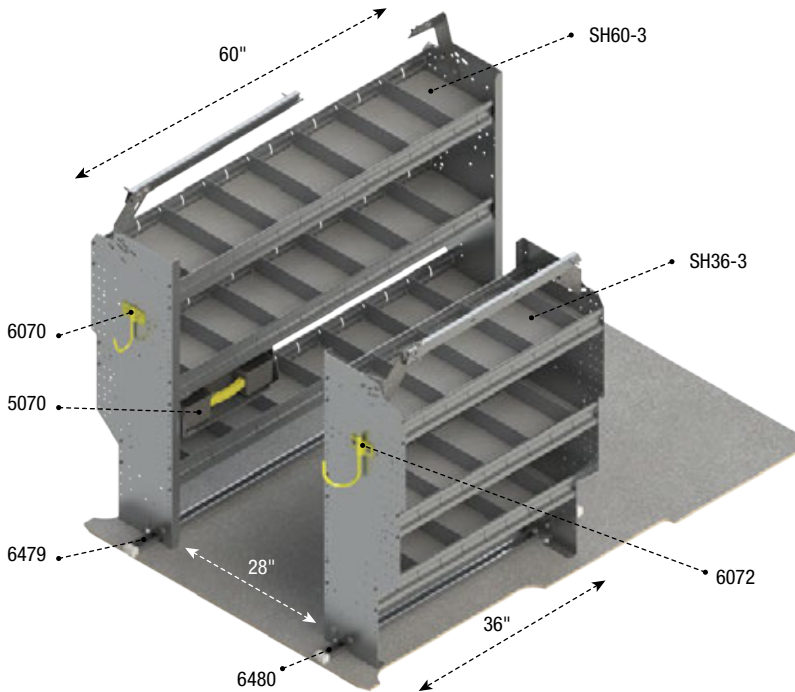

122"	Standard	123 lbs
2.7 hrs	Yes	

Qty	Part #	Description
1	5070	Partskeeper carry case with holder, universal
1	6070	6" Hook, 3" opening, painted
1	6072	8" Swivel Hook, 4" opening, painted
1	6479	Shelving install kit
1	6480	Shelving install kit
1	SH36-3	Contoured Shelving Unit with Dividers
1	SH60-3	Contoured Shelving Unit with Dividers

**RANGER**  
FLEETLINE

**DRAWER UNIT**  
3 DRAWERS  
BALL BEARING SLIDE

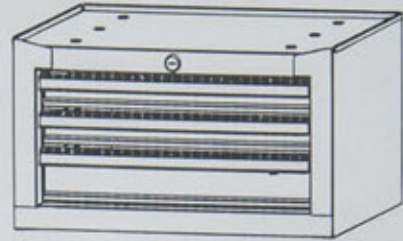

**RANGER**  
DESIGN

[www.rangerdesign.com](http://www.rangerdesign.com) 1-800-8

**RANGER**  
FLEETLINE  
DRAWER UNIT

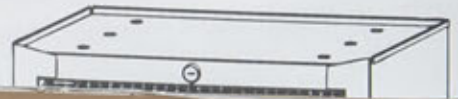

**EDACIL E**



# H319

## Delivery

### **TOUGH**

Extrusion builds durability into shelf.

### **QUIET**

The combination of the extrusion, shelf tray, and end-panels create durable, vibration-free shelves.

### **EFFICIENT**

Ergonomic design reduces injuries and increases productivity.



\*Preproduction model shown,  
do not use as an installation guide.

# H319

Aluminum

Base Delivery Package

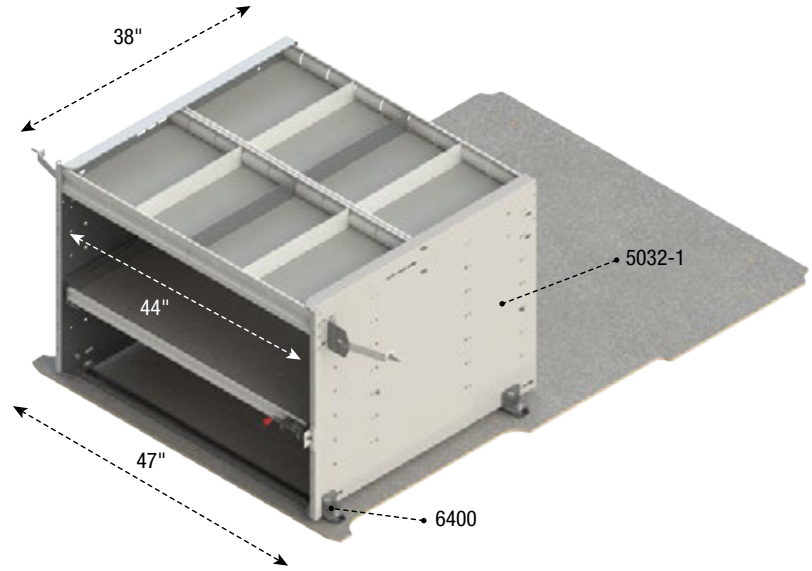

PACKAGES



## H319

122"	Standard	89 lbs
1 hr	Yes	

Qty	Part #	Description
1	5032-1	Axess Tray with 1 shelf / 1 drawer
1	6400	Axess Tray install kit

ADD YOUR  
**ACCESSORIES**  
P.50



PICK YOUR  
**PARTITION**  
P.10



CHOOSE YOUR  
**LADDER RACK**  
P.61



# H419

Aluminum

Deluxe Delivery Package

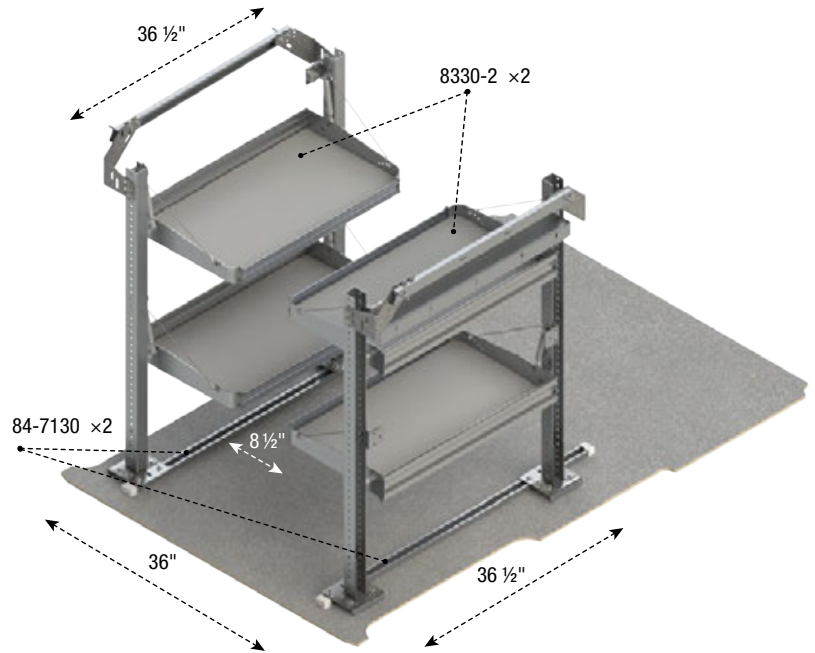

## H419

122"

Standard

106 lbs

3.2 hrs

Yes

Qty	Part #	Description
2	8330-2	Fold-Away Shelving
2	84-7130	Shelving install kit

## RANGER DESIGN 9 DRAWER CABINET

**X51-F** The new steel 9-drawer cabinet will fit any package or upfit

- > Great for organizing small parts
- > Affordably priced
- > Easily installs side by side or stacked vertically

P.46



# SHELVING

Industry leading strength.  
The perfect fit for the toughest jobs.

## CONTOURED UNITS

- CONTOURED BIN SHELVING UNIT . . . . . P. 37
- CONTOURED REFRIGERANT BIN UNIT . . . . . P. 37
- CONTOURED SHELVING UNIT . . . . . P. 37
- CONTOURED SHELVING UNIT W/ DIVIDERS . . . . . P. 39
- SHELVING DOORS . . . . . P. 40

## FOLD-AWAY SHELVING . . . . . P. 39

Ranger Design shelving is built strong and durable and often outlasts the vehicle. Designed to fit with maximum efficiency, Ranger shelving optimizes the space in a work van's cargo area.



**TOUGH**  
Extrusion builds durability into shelf



**QUIET**  
Shelf tray, end panel and extrusion are engineered to be vibration free









**ORGANIZED**  
A well-Planned van outfit increases productivity

# CONTOURED BIN SHELVING UNIT – SHELVING

## Contoured Bin Shelving Unit

### Aluminum

							
<b>BH36</b>	15" D x 36" W x 45" H	64 lbs			18 (sm), 18 (md)	1 hr	Yes
<b>BH48</b>	15" D x 48" W x 45" H	81 lbs			24 (sm), 24 (md)	1 hr	No
<b>BH60</b>	15" D x 60" W x 45" H	97 lbs			30 (sm), 30 (md)	1 hr	No



## Contoured Bin Shelving Unit

### Steel

							
<b>H36-H</b>	15" D x 36" W x 45" H	54 lbs				1 hr	Yes



## Contoured Refrigerant Bin Unit







### Aluminum

							
<b>RH36</b>	15" D x 36" W x 45" H	43 lbs		3	9 (sm), 6 (lrg)	1 hr	Yes
<b>RH48</b>	15" D x 48" W x 45" H	52 lbs		4	12 (sm), 8 (lrg)	1 hr	No
<b>RH60</b>	15" D x 60" W x 45" H	62 lbs		5	15 (sm), 10 (lrg)	1 hr	No



## Contoured Shelving Unit

### Steel

							
<b>L36-H</b>	15" D x 36" W x 45" H	48 lbs				1 hr	No
<b>L60-H</b>	15" D x 60" W x 45" H	64 lbs				1 hr	No



# CONTOURED BIN **SHELVING UNITS**



BH36

## **BENEFIT**

Engineered to maximize cargo space.







These unique shelf designs are quiet and will stand up to years of rugged use.

F36-H

# CONTOURED SHELVING UNIT – SHELVING

## Contoured Shelving Unit with Dividers







### Aluminum

							
<b>SH36-3</b>	15" D x 36" W x 45" H	41 lbs	3 Shelves (13", 12", 8")	12	7728	1 hr	Yes
<b>SH48-3</b>	15" D x 48" W x 45" H	49 lbs	3 Shelves (13", 12", 8")	18	7725	1 hr	No
<b>SH60-3</b>	15" D x 60" W x 45" H	58 lbs	3 Shelves (13", 12", 8")	21	7727	1 hr	Yes



## Contoured Shelving Unit with Dividers







### Aluminum

							
<b>SH36-4</b>	15" D x 36" W x 45" H	50 lbs	4 Shelves (13", 13", 12", 8")	16	7723	1 hr	No
<b>SH48-4</b>	15" D x 48" W x 45" H	62 lbs	4 Shelves (13", 13", 12", 8")	16	7720	1 hr	No
<b>SH60-4</b>	15" D x 60" W x 45" H	74 lbs	4 Shelves (13", 13", 12", 8")	28	7722	1 hr	No



## Contoured Shelving Unit with Dividers







### Steel

							
<b>F36-H</b>	15" D x 36" W x 45" H	41 lbs	3 Shelves (8", 12", 13")	4	Y11-E	1 hr	Yes
<b>F60-H</b>	15" D x 60" W x 45" H	53 lbs	3 Shelves (8", 12", 13")	8		1 hr	Yes



## Fold-Away Shelving

### Aluminum

							
<b>8330-2</b>	18" D x 37" W x 46.5" H	45 lbs	2 Shelves (17", 17")			1.3 hrs	Yes

\*Weight capacity for fold-away shelving is 65 lbs / linear foot.







# SHELVING – DOORS



Shelving Doors



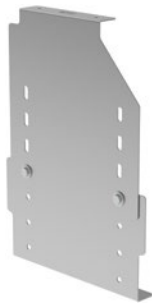

## Aluminum

		Use with shelf width			
<b>7720</b>	44.88" W x 8.69" H	48", 96"	7 lbs	0.5 hr	No
<b>7722</b>	56.88" W x 8.69" H	60"	9 lbs	0.5 hr	No
<b>7723</b>	32.88" W x 8.69" H	36", 72"	5 lbs	0.5 hr	No
<b>7724</b>	20.88" W x 8.69" H	24"	4 lbs	0.5 hr	No
<b>7725</b>	44.88" W x 10.38" H	48", 96"	8 lbs	0.5 hr	Yes
<b>7727</b>	56.88" W x 10.38" H	60"	9 lbs	0.5 hr	No
<b>7728</b>	32.88" W x 10.38" H	36", 72"	6 lbs	0.5 hr	Yes
<b>7729</b>	20.88" W x 10.38" H	24"	4 lbs	0.5 hr	No
<b>7730</b>	44.88" W x 12.06" H	48", 96"	8 lbs	0.5 hr	Yes
<b>7731</b>	38.88" W x 12.06" H	84"	8 lbs	0.5 hr	No
<b>7732</b>	56.88" W x 12.06" H	60"	10 lbs	0.5 hr	No
<b>7733</b>	32.88" W x 12.06" H	36", 72"	6 lbs	0.5 hr	No
<b>7734</b>	20.88" W x 12.06" H	24"	5 lbs	0.5 hr	No
<b>7735</b>	44.88" W x 13.75" H	48", 96"	9 lbs	0.5 hr	No
<b>7737</b>	56.88" W x 13.75" H	60"	11 lbs	0.5 hr	No
<b>7738</b>	32.88" W x 13.75" H	36", 72"	7 lbs	0.5 hr	No
<b>7739</b>	20.88" W x 13.75" H	24"	5 lbs	0.5 hr	No



Shelf Block





## Aluminum

		Use with shelf width			
<b>7740</b>	12" W x Adjustable from 11¼" to 16 5/16"	All	3 lbs	0.5 hr	No



Shelving Doors





## Steel

		Use with shelf width			
<b>Y10-C</b>	34.88" W x 8.69" H	70"	9 lbs	0.5 hr	Yes
<b>Y10-D</b>	37.88" W x 8.69" H	38"	10 lbs	0.5 hr	No
<b>Y10-F</b>	41.88" W x 8.69" H	42", 87"	12 lbs	0.5 hr	Yes
<b>Y10-H</b>	47.88" W x 8.69" H	48"	14 lbs	0.5 hr	No
<b>Y10-M</b>	31.88" W x 8.69" H	32"	8 lbs	0.5 hr	No
<b>Y11-C</b>	34.88" W x 10.38" H	70"	10 lbs	0.5 hr	Yes
<b>Y11-D</b>	37.88" W x 10.38" H	38"	11 lbs	0.5 hr	Yes
<b>Y11-E</b>	35.88" W x 10.38" H	36"	10.5 lbs	0.5 hr	No
<b>Y11-F</b>	41.88" W x 10.38" H	42", 87"	13 lbs	0.5 hr	Yes
<b>Y11-M</b>	31.88" W x 10.38" H	32"	8 lbs	0.5 hr	No
<b>Y12-C</b>	34.88" W x 12.06" H	70"	10 lbs	0.5 hr	No
<b>Y12-D</b>	37.88" W x 12.06" H	38"	12 lbs	0.5 hr	No
<b>Y12-F</b>	41.88" W x 12.06" H	42", 87"	14 lbs	0.5 hr	No
<b>Y12-M</b>	31.88" W x 12.06" H	32"	8 lbs	0.5 hr	No



Shelving Doors

## Steel

		Use with shelf width			
<b>Y10-J</b>	55.88" W x 8.69" H	56"	15 lbs	0.5 hr	No
<b>Y11-J</b>	55.88" W x 10.38" H	56"	16 lbs	0.5 hr	No
<b>Y12-J</b>	55.88" W x 12.06" H	56"	17 lbs	0.5 hr	No





**TOUGH**

Proline drawers are backed by a 10 year warranty.



**QUICK**

Easy to use slam latch.



**SECURE**

Keyed lock to guard valuables.

# DRAWERS

Durable storage compartments, designed for quick and easy access.

AXESS TRAYS . . . . . P. 42

COMPACT DRAWERS . . . . . P. 45

DRAWER CABINETS . . . . . P. 44

PARTSKEEPERS . . . . . P. 46

PARTSLIDERS . . . . . P. 44

TOOL DRAWERS . . . . . P. 48

Ranger manufactures a variety of tough, quiet drawer systems and storage modules. Using top quality components such as full-extension, high-capacity ball-bearing drawer slides, secure locks, and Ranger's unique braided stainless steel cable-pull handles. These drawers are the organizational quality that you deserve.

If you never again want to experience the frustration of drawers that jam, sag, and don't latch properly, we have the solution.



# DRAWERS



## 5032-0

Axess Tray with 1 shelf / no drawers

### Aluminum

38" D x 45" W x 30" H

—

51 lbs

0.9 hr

No



## 5032-1

Axess Tray with 1 shelf / 1 drawer

### Aluminum

38" D x 45" W x 30" H

200 lbs

89 lbs

1 hr

Yes



## 5032-2

Axess Tray with 1 shelf / 2 drawers

### Aluminum

38" D x 45" W x 30" H

200 lbs

127 lbs

1.1 hrs

No



## 5032-3

Axess Tray with 1 shelf / 3 drawers

### Aluminum

38" D x 45" W x 30" H

200 lbs

165 lbs

1.2 hrs

No



## 5032-A

Axess Tray drawer only,  
complete with slides

### Aluminum

38" D x 45" W

—

38 lbs

—

No

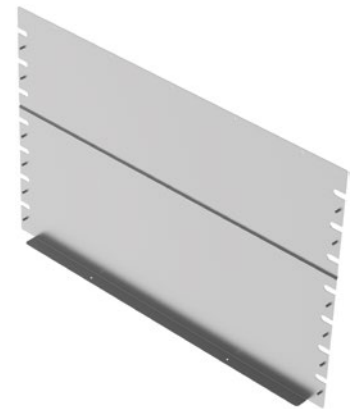

## 5032-F

Axess Tray full back panel for 5032 series

### Aluminum

41" W x 27.25" H

—

8 lbs

0.25 hr

No



### 5037-0

Axess Tray with 1 shelf / no drawers

#### Aluminum

38" D x 45" W x 42" H

—

55 lbs

1 hr

No



### 5037-1

Axess Tray with 1 shelf / 1 drawer

#### Aluminum

38" D x 45" W x 42" H

200 lbs

93 lbs

1.1 hrs

No



### 5037-2

Axess Tray with 1 shelf / 2 drawers

#### Aluminum

38" D x 45" W x 42" H

200 lbs

131 lbs

1.2 hrs

No



### 5037-3

Axess Tray with 1 shelf / 3 drawers

#### Aluminum

38" D x 45" W x 42" H

200 lbs

169 lbs

1.3 hrs

No



### 5037-A

Axess Tray drawer only, c/w slides

#### Aluminum

38" D x 45" W

—

38 lbs

—

No

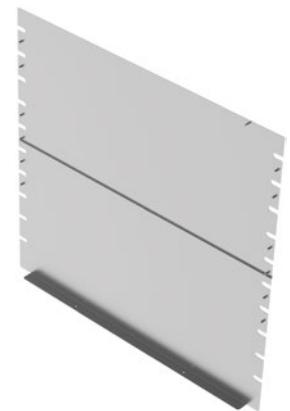

### 5037-F

Axess Tray full back panel for 5037 series

#### Aluminum

41" W x 39.25" H

—

11 lbs

0.25 hr

No



# DRAWERS

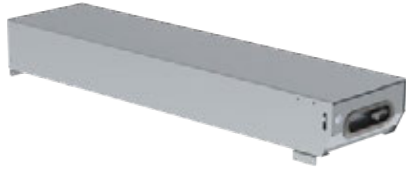

## 5010

Partslider drawer

### Aluminum

	48" D x 12" W x 6" H
	150 lbs
	30 lbs
	0.5 hr
	Yes



## 5011

Partslider drawer

### Aluminum

	36" D x 12" W x 6" H
	150 lbs
	26 lbs
	0.5 hr
	No



## 5014

Floor mount kit for 5010 / 5011 Partslider drawer

### Aluminum

	-
	-
	1 lb
	-
	No



## 5048

Top edge, for 5010 Partslider

### Aluminum

	48" D x 12" W x 4" H
	-
	5 lbs
	0.2 hr
	Yes



## 5051

Top edge, for 5011 Partslider

### Aluminum

	36" D x 12" W x 4" H
	-
	4 lbs
	0.2 hr
	No



## 5060-5

5 Drawer cabinet and 1 door

### Aluminum

	18" D x 24" W x 36" H
	150 lbs
	104 lbs
	1 hr
	No



## 5060-6

6 Drawer cabinet

### Aluminum

18" D x 24" W x 36" H

150 lbs

114 lbs

1 hr

No



## 5060-8

8 Drawer cabinet

### Aluminum

18" D x 24" W x 36" H

150 lbs

148 lbs

1 hr

No



## 5067-6

6 Drawer cabinet

### Aluminum

18" D x 18" W x 28" H

150 lbs

97 lbs

0.5 hr

No



## 5068-3

3 Drawer cabinet

### Aluminum

18" D x 15" W x 15" H

150 lbs

45 lbs

0.5 hr

Yes



## 5069-2

2 Drawer cabinet

### Aluminum

14" D x 24" W x 12" H

150 lbs

34 lbs

0.5 hr

Yes



## X50-B

Compact 2-Drawer Unit

### Steel

12.5" D x 18.5" W x 10.5" H

—

19 lbs

0.3 hr

Yes



# DRAWERS



## X50-C

Compact 3-Drawer Unit

### Steel

12.5" D x 18.5" W x 10.5" H



20 lbs

0.3 hr

Yes



## X51-F

Compact 9-Drawer Unit

### Steel

12" D x 17" W x 12" H



26 lbs

0.3 hr

Yes

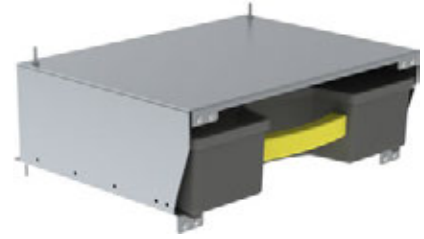

## 5070

Partskeeper carry case with holder, universal

### Aluminum

14" D x 17" W x 5.5" H



7 lbs

0.3 hr

Yes



**X50-B** Compact 3-Drawer Unit and **X50-C** Compact 2-Drawer Unit combined.



## 5072

Partskeeper carry case with holder, floor mount

### Aluminum

14" D x 17" W x 8.75" H

—

7 lbs

0.3 hr

No



## 5078

Partskeeper cabinet with 4 carry cases

### Aluminum

14" D x 17" W x 24" H

—

23 lbs

0.3 hr

Yes

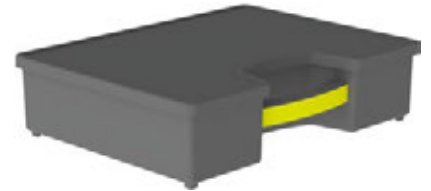

## 5079

Partskeeper carry case

### Plastic

13" D x 16.5" W x 4" H

—

3 lbs

—

No



5020 Tool drawer mounted with its complementary 5010 Partslider drawer and 5048 Top edge.

### LEGEND



Dimensions



Weight Capacity



Weight



Install Time



Quickship

# DRAWERS



## 5082

Partskeeper cabinet with 8 carry cases

### Aluminum

14" D x 17" W x 43" H

—

54 lbs

1 hr

Yes



## 5083

Partskeeper cabinet with 5 carry cases & 2 shelves

### Aluminum

14" D x 17" W x 43" H

—

41 lbs

1 hr

Yes



## 5020

Tool drawer

### Aluminum

48" D x 14" W x 16" H

320 lbs

70 lbs

1 hr

Yes

DRAWERS



Two **5082** Partskeeper cabinet mounted side by side.





## 5021

Tool drawer

### Aluminum

36" D x 14" W x 16" H

320 lbs

60 lbs

1 hr

No



## 5025

Jumbo tool drawer

### Aluminum

48" D x 16" W x 19" H

320 lbs

84 lbs

1 hr

Yes



## 5026

Jumbo tool drawer

### Aluminum

36" D x 16" W x 19" H

320 lbs

73 lbs

1 hr

No

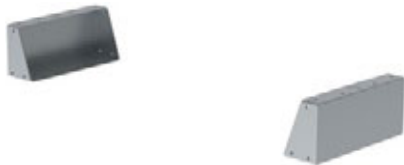

## 5028

Raised base for 5020 tool drawer

### Aluminum

6" D x 14" W x 6" H

—

8 lbs

0.5 hr

No



## 5029

Raised base for 5025 Jumbo tool drawer

### Aluminum

6" D x 16" W x 6" H

—

8 lbs

0.5 hr

No



## X02-A

Fleetline Tool Drawer

### Steel

45.5" D x 13.5" W x 22" H

—

80 lbs

1 hr

Yes

# ACCESSORIES

Choose the finishing details to tailor the upfit to your specific needs.

BINS .....	P. 51
BOTTLE HOLDERS .....	P. 52
HOOKS .....	P. 54
LOCKING CABINETS .....	P. 53
OTHERS .....	P. 53
PAPER HOLDERS .....	P. 57
WINDOW GRILLS .....	P. 59

The finishing details are just as important when you're setting up your commercial van as they are when you're on the job site. Customize your vehicle with our wide range of options to ensure that you can perform at peak efficiency.



## VERSATILE

Removable storage bins ensure organization on the jobsite or on the go.



## SECURE

Trade specific accessories with a place for all tools and supplies.



## PRODUCTIVE

Stay productive with the most used items well within reach.

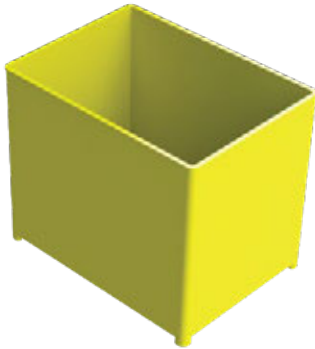

**6205**  
Bin cup

Plastic	
4.5" D x 3.25" W x 3.75" H	
0.12 lb	
-	
No	



**6211**  
Small Bin, Graphite

Plastic	
6.5" D x 4" W x 3" H	
0.24 lb	
-	
Yes	

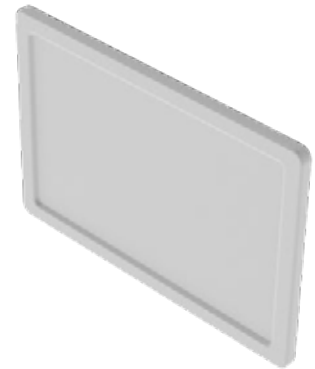

**6212**  
Divider for 6211 small bin

Aluminum	
-	
-	
-	
No	



**6221**  
Medium Bin, Graphite

Plastic	
10" D x 6" W x 4.5" H	
0.56 lb	
-	
Yes	



**6222**  
Divider for 6221 medium bin

Aluminum	
-	
-	
-	
No	



**6231**  
Large Bin, Graphite

Plastic	
14" D x 8" W x 5.5" H	
1.33 lbs	
-	
Yes	

# ACCESSORIES

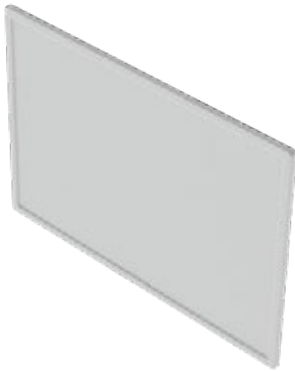

## 6232

Divider for 6231 large bin

### Aluminum

—

—

—

No



## 6006

3 Tier refrigerant rack for small bottles

### Aluminum

14" D x 10.5" W x 43" H

24 lbs

0.6 hr

No



## 6007

4 Tier refrigerant rack for small bottles

### Aluminum

14" D x 10.5" W x 43" H

22 lbs

0.6 hr

Yes



## 6008

3 Tier refrigerant rack for large bottles

### Aluminum

14" D x 13" W x 43" H

25 lbs

0.6 hr

No



## 6010

Two level adjustable bottle holder

### Aluminum

10.25" D x 9.5" W x 36" H

5 lbs

0.4 hr

No



## 6020

Horizontal refrigerant bottle holder

### Aluminum

12.5" D x 48" W x 13" H

17 lbs

0.5 hr

No



**6040**

Locking cabinet

**Aluminum**

8.5" D x 12" W x 24" H

16 lbs

0.6 hr

No



**6041**

Locking cabinet

**Aluminum**

15" D x 15.5" W x 33" H

26 lbs

0.7 hr

No

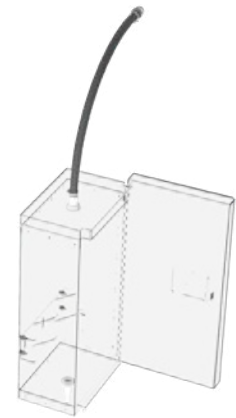

**6049**

Ventilation kit for cabinet

**Aluminum**

-

-

-

No

NEW RANGER DESIGN  
**GRAPHITE BINS**



**BENEFIT**

New graphite bin color provides a neutral balance that allows for more light and blends easily with existing colors.

# ACCESSORIES

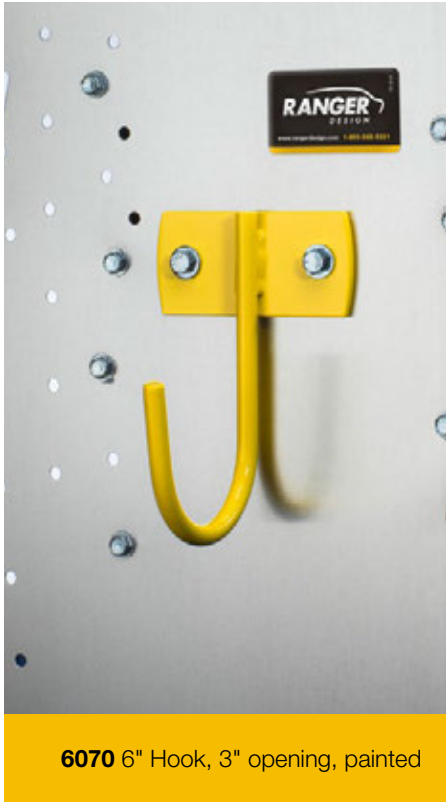

**6070** 6" Hook, 3" opening, painted



## 6088

Large aluminum bottle holder, comes with two black nylon straps

### Aluminum

8" W x 24" H

2 lbs

0.2 hr

Yes



## 6086

Small aluminum bottle holder, comes with a black nylon strap

### Aluminum

6" W x 12" H

1 lb

0.2 hr

Yes

ACCESSORIES



## 6070

6" Hook, 3" opening, painted

### Steel

3" D

0.4 lb

0.2 hr

Yes



## 6072

8" Swivel Hook, 4" opening, painted

### Steel

4" D

0.6 lb

0.2 hr

Yes



## 6073

Large aluminum movable hook, 6.5" opening

### Aluminum

6.5" D x 2.75" W x 4" H

1 lb

0.01 hr

Yes



## Y30-C

Coat Hook, 1" opening, chrome plated

### Steel

1" D

0.1 lb

0.2 hr

Yes



## 1130

Elevated strobe mount

### Aluminum

8" W

1 lb

0.1 hr

No

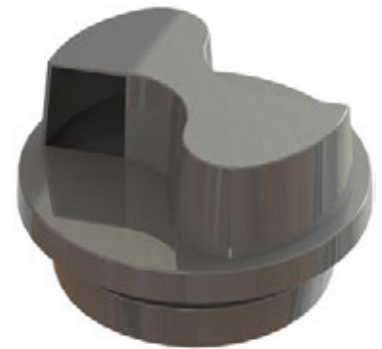

## 6050

Flettner vent, rotary design

### Plastic

8.88" D

1.5 lbs

1 hr

No



## 6052

Vise Holder with an 8"x8" mounting plate

### Steel

—

37 lbs

0.5 hr

No



## 6054

Hitch Step, comes with hitch pin to fit a 2"x2" hitch

### Aluminum

6" D x 12" W

4 lbs

—

No



## 6057

Can Holder

### Aluminum

3" D x 8.5" W x 3" H

1 lb

0.2 hr

No

# ACCESSORIES



## 6075

Transport tube door, for 6" diameter tube with stainless steel hardware

### Aluminum

□ 6" D

⬆ 2 lbs

⌚ 0.2 hr

⚙ No



## 6078

Cradle & strap kit for 6" dia. transport tube (one cradle and one strap)

### Aluminum

□ 6" D

⬆ 1 lb

⌚ 0.1 hr

⚙ No

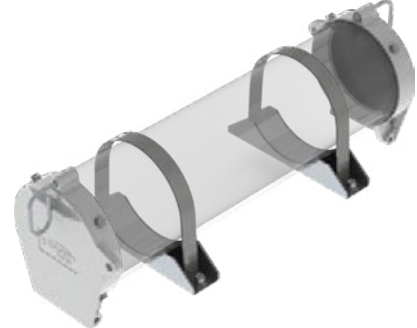

## 6079

Transport tube door kit complete (Tube not included)

### Aluminum

□ 6" D

⬆ 6 lbs

⌚ 0.8 hr

⚙ No

ACCESSORIES



## 6082

Triangle kit with aluminum holder

### Other

□ -

⬆ 14 lbs

⌚ 0.2 hr

⚙ No



## 6090

Back up alarm, die cast housing, fully encapsulated circuitry

### Other

□ -

⬆ 1 lb

⌚ 1 hr

⚙ No



## 6091

Surface mount tie down ring, zinc plated

### Steel

□ 4" D

⬆ 0.4 lb

⌚ 0.2 hr

⚙ No





## 6092

Dome Light, chrome finish housing

### Other

8.5" D

1 lb

1 hr

No



## 6093

Grab handle

### Plastic

9.5" D

0.1 lb

0.5 hr

No



## 7124

Reel Holder with two 5/8" diameter rods

### Aluminum

7.25" D x 15" W x 24" H

9 lbs

0.5 hr

No



## 6061

Paper Holder, extra deep, 2 slots

### Aluminum

3.75" D x 12.75" W x 12" H

2 lbs

0.2 hr

No



## 6063

Paper Holder, extra deep, 5 slots

### Aluminum

3.75" D x 12.75" W x 24" H

5 lbs

0.2 hr

Yes



## 6066

2 Pocket Holder, comes with 8 plastic bins

### Aluminum

4.5" D x 20" W x 21.75" H

7.5 lbs

0.2 hr

No

# ACCESSORIES



## 6067

Paper Holder, regular depth, 2 slots

### Aluminum

2.25" D x 12.75" W x 12" H

2 lbs

0.2 hr

No



## 6068

Hard Hat Holder, painted wire

### Steel

—

0.5 lb

0.2 hr

No



## 6069

Paper Holder, regular depth, 5 slots

### Aluminum

2.25" D x 12.75" W x 24" H

5 lbs

0.2 hr

No



## Y31-A

Paper Holder, extra deep, 3 slots

### Steel

3.75" D x 12.75" W x 16" H

9 lbs

0.2 hr

Yes



## 6095

Black nylon strap, plastic buckle

### Other

2" W x 28" H

0.18 lb

0.01 hr

No



## 6096

Black Nylon Strap, chrome plated buckle

### Other

1" W x 36" H

0.12 lb

0.01 hr

No



## 6097

Black Nylon Strap, chrome plated buckle

### Other

1" W x 48" H

0.13 lb

0.01 hr

No



## 6098

Black Nylon Strap, chrome plated buckle

### Other

1" W x 72" H

0.16 lb

0.01 hr

No

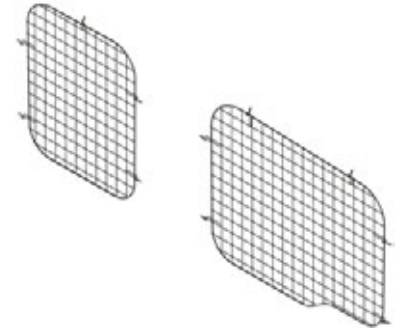

## 6134

Set of 2 rear window grills

### Steel

Standard Roof

8 lbs

0.2 hr

No

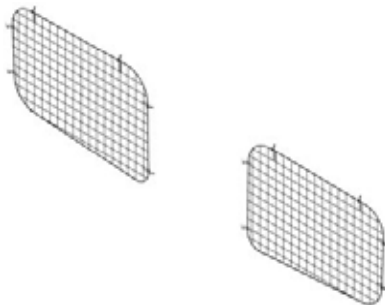

## 6135

Set of 2 sliding door window grills

### Steel

Standard Roof

8 lbs

0.2 hr

No

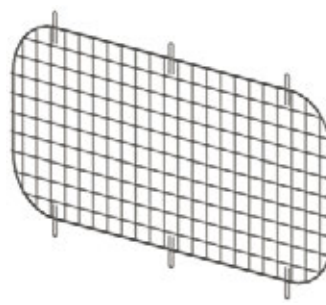

## 3044

Grill for partition window for 3020, 3025, 3068 and 3069

### Steel

Universal

2 lbs

0.5 hr

No



## 3024

Partition window with frame for 3020, 3025, 3068 and 3069

### Aluminum

Universal

5 lbs

0.5 hr

No

INTRODUCING THE NEW RANGER DESIGN

# SEAT COVERS





## OUR KEY ADVANTAGES INCLUDE:

- › Durable material and easy maintenance
- › Urethane coating to make the fabric water and stain resistant
- › Machine wash and dryer safe
- › Easy installation of 30 minutes or less for a set
- › No interference with factory seat functions (heating, cooling or air bag)
- › Minimal seams
- › Tight custom fit for each vehicle, guaranteed to stay in place
- › Puncture resistant to prevent seat damage
- › Durable Cordura® fabric with a 1 year warranty

6253

## SPECIFICATIONS

for 1 set of bucket seat covers

	4 lbs
	0.5 hr
	Yes

**THE PERFECT FIT**  
FOR YOUR TOUGHEST JOBS

**RANGER**<sup>TM</sup>  
DESIGN

*Our Promise: To Help You Work More Effectively by Providing Organized Storage Solutions.*



### **TOUGH**

Military grade aluminum extrusion, high density plastic and stainless steel components ensure no corrosion over the lifetime of the rack.



### **QUIET**

Aerodynamic design with minimal wind noise.



### **SAFE**

No metal contact to ladder, leading to longer life of ladders with less chance of fiberglass splinters.

## **LADDER RACKS**

Ergonomic Ladder Racks make loading and unloading easier.

Ranger Design's ladder racks make loading and unloading ladders an easy operation. Ranger Design offers drop-down ladder racks for high roof vans; extra tough racks capable of carrying 28' ladders on compact vans; interior ladder carriers and many other options for different applications.

**Please take note that all our ladder racks are powder-coated white.**



**RANGER**<sup>TM</sup>  
DESIGN

# LADDER RACKS



Cargo rack

Aluminum

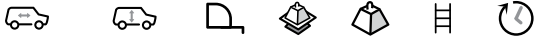

**1505-PC** 122" Standard 60" W 480 lbs 28 lbs 0.8 hr



Combination ladder rack

Aluminum

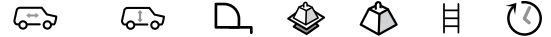

**1525-PC** 122" Standard 60" W 400 lbs 60 lbs 24 ft 1.7 hrs



Standard ladder rack

Aluminum

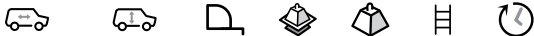

**1510-PC** 122" Standard 60" W 400 lbs 28 lbs 0.9 hr



Combination ladder rack

Aluminum

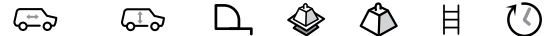

**1525-PCX** 122" Standard 60" W 400 lbs 69 lbs 28 ft 2.1 hrs



Single clamp ladder rack

Aluminum

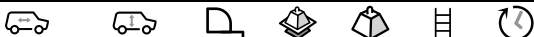

**1520-PC** 122" Standard 60" W 400 lbs 40 lbs 24 ft 1.2 hrs



Double clamp ladder rack

Aluminum

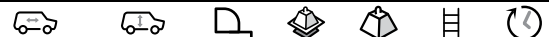

**1530-PC** 122" Standard 60" W 400 lbs 52 lbs 24 ft 1.7 hrs

LADDER RACKS



Double clamp ladder rack

**Aluminum**

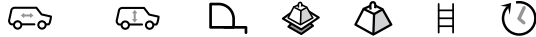

<b>1530-PCX</b>	122"	Standard	60" W	450 lbs	61 lbs	28 ft	2 hrs
-----------------	------	----------	-------	---------	--------	-------	-------



Access Pro, Inside Ladder Carrier

**Aluminum**

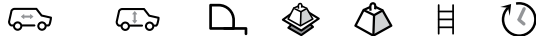

<b>1050-M</b>	122"	Standard	60" W	9 lbs			1 hr
---------------	------	----------	-------	-------	--	--	------



Ladder rack accessory

**Aluminum**



<b>1127</b>	122"	Standard	23" W	18 lbs			0.5 hr
-------------	------	----------	-------	--------	--	--	--------

## INSTALL KITS



Product #	ProMaster City
5025, 5020, X02-A	6428
32" Shelving Driver side	-
32" Shelving Passenger side	-
36" Shelving Driver side	6480
36" Shelving Passenger side	6480
All 56" Shelving	-
60" Shelving Driver side	6479
60" Shelving Passenger side	6479
Axess Tray	6400
Fold Away Shelving Driver side	84-7130
Fold Away Shelving Passenger side	84-7130

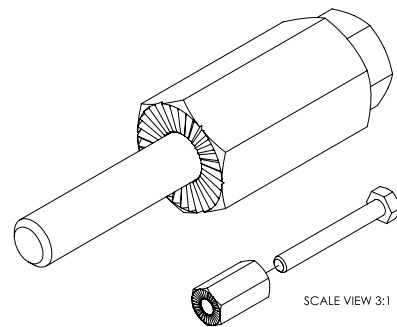

The Plus Nut/Riv-Nut tool (#6490) is available at no charge upon request.

# Over 350 Distributors Across the Continent

## Regular Order

## Quickship Order

**Buy**

Contact one of our 350 distributors  
[rangerdesign.com/find-dealer](http://rangerdesign.com/find-dealer).

Ranger Quickship service is available  
through your local distributor.

**Lead  
Time**

Orders ship from our factory within  
5 business days.

Orders placed with Ranger before 1PM EST will  
ship from our factory in the next business day.



Throughout the catalog products and packages with this symbol  
can be ordered through our Quickship service.



# Turn-Key Fleet Services



## Ship Through or Local Installation Across North America for all Types of Cargo Vans

We are pleased to offer efficient, personalized service and to answer all questions regarding:

### 1. Analysis

- › Cargo Needs Analysis
- › Custom 3D CAD Layouts
- › Hands-on Equipment Demo

### 2. Testing

- › Test Fitting
- › Pilot Build and Review
- › Optimize Package Based on Technician Feedback

### 3. Delivery

- › Delivery, Production and Installation Planning and Scheduling
- › Vehicle Status Tracking

### 4. Service

- › Dedicated Fleet Account Management Team
- › 300 Ranger Distributor Service Support Network
- › Live Customer Service

# INDEX

1050-M . . . . .	63	5079 . . . . .	47	6490 . . . . .	63	SH60-3 . . . . .	39
1127 . . . . .	63	5082 . . . . .	48	6540-PC . . . . .	9	SH60-4 . . . . .	39
1130 . . . . .	55	5083 . . . . .	48	7124 . . . . .	57	X02-A . . . . .	49
1505-PC . . . . .	62	6006 . . . . .	52	7720 . . . . .	40	X50-B . . . . .	45
1510-PC . . . . .	62	6007 . . . . .	52	7722 . . . . .	40	X50-C . . . . .	46
1520-PC . . . . .	62	6008 . . . . .	52	7723 . . . . .	40	X51-F . . . . .	46
1525-PC . . . . .	62	6010 . . . . .	52	7724 . . . . .	40	Y10-C . . . . .	40
1525-PCX . . . . .	62	6020 . . . . .	52	7725 . . . . .	40	Y10-D . . . . .	40
1530-PC . . . . .	62	6040 . . . . .	53	7727 . . . . .	40	Y10-F . . . . .	40
1530-PCX . . . . .	63	6041 . . . . .	53	7728 . . . . .	40	Y10-H . . . . .	40
3010-PC . . . . .	12	6049 . . . . .	53	7729 . . . . .	40	Y10-J . . . . .	40
3020-PC . . . . .	13	6050 . . . . .	55	7730 . . . . .	40	Y10-M . . . . .	40
3024 . . . . .	59	6052 . . . . .	55	7731 . . . . .	40	Y11-C . . . . .	40
3044 . . . . .	59	6054 . . . . .	55	7732 . . . . .	40	Y11-D . . . . .	40
3310-PC . . . . .	12	6057 . . . . .	55	7733 . . . . .	40	Y11-E . . . . .	40
3320-PC . . . . .	12	6061 . . . . .	57	7734 . . . . .	40	Y11-F . . . . .	40
5010 . . . . .	44	6063 . . . . .	57	7735 . . . . .	40	Y11-J . . . . .	40
5011 . . . . .	44	6066 . . . . .	57	7737 . . . . .	40	Y11-M . . . . .	40
5014 . . . . .	44	6067 . . . . .	58	7738 . . . . .	40	Y12-C . . . . .	40
5020 . . . . .	48	6068 . . . . .	58	7739 . . . . .	40	Y12-D . . . . .	40
5021 . . . . .	49	6069 . . . . .	58	7740 . . . . .	40	Y12-F . . . . .	40
5025 . . . . .	49	6070 . . . . .	54	8330-2 . . . . .	39	Y12-J . . . . .	40
5026 . . . . .	49	6072 . . . . .	54	BH36 . . . . .	37	Y12-M . . . . .	40
5028 . . . . .	49	6073 . . . . .	54	BH48 . . . . .	37	Y30-C . . . . .	55
5029 . . . . .	49	6075 . . . . .	56	BH60 . . . . .	37	Y31-A . . . . .	58
5032-0 . . . . .	42	6078 . . . . .	56	C10-PC . . . . .	13	Z10-H3 . . . . .	18
5032-1 . . . . .	42	6079 . . . . .	56	C12-PC . . . . .	13	Z10-H4 . . . . .	19
5032-2 . . . . .	42	6082 . . . . .	56	C13-PC . . . . .	13	Z16-H3 . . . . .	30
5032-3 . . . . .	42	6086 . . . . .	54	F36-H . . . . .	39	Z16-H4 . . . . .	30
5032-A . . . . .	42	6088 . . . . .	54	F60-H . . . . .	39		
5032-F . . . . .	42	6090 . . . . .	56	H311 . . . . .	22		
5037-0 . . . . .	43	6091 . . . . .	56	H312 . . . . .	26		
5037-1 . . . . .	43	6092 . . . . .	57	H316 . . . . .	31		
5037-2 . . . . .	43	6093 . . . . .	57	H319 . . . . .	34		
5037-3 . . . . .	43	6095 . . . . .	58	H36-H . . . . .	37		
5037-A . . . . .	43	6096 . . . . .	58	H411 . . . . .	23		
5037-F . . . . .	43	6097 . . . . .	59	H412 . . . . .	27		
5048 . . . . .	44	6098 . . . . .	59	H416 . . . . .	31		
5051 . . . . .	44	6134 . . . . .	59	H419 . . . . .	35		
5060-5 . . . . .	44	6135 . . . . .	59	L36-H . . . . .	37		
5060-6 . . . . .	45	6205 . . . . .	51	L60-H . . . . .	37		
5060-8 . . . . .	45	6211 . . . . .	51	RH36 . . . . .	37		
5067-6 . . . . .	45	6212 . . . . .	51	RH48 . . . . .	37		
5068-3 . . . . .	45	6221 . . . . .	51	RH60 . . . . .	37		
5069-2 . . . . .	45	6222 . . . . .	51	SH36-3 . . . . .	39		
5070 . . . . .	46	6231 . . . . .	51	SH36-4 . . . . .	39		
5072 . . . . .	47	6232 . . . . .	52	SH48-3 . . . . .	39		
5078 . . . . .	47	6253 . . . . .	60	SH48-4 . . . . .	39		

SEE CLEARLY NOW, INTRODUCING THE REVOLUTIONARY

# MAX VIEW SAFETY PARTITION



WINNER OF

**THE  
WORK  
TRUCK  
SHOW**  
2016

2016  
**INNOVATION  
AWARD**

The Ranger Design Max View gives you 180 degree rear visibility into the cargo area – giving you the safety and comfort you deserve

This state-of-the-art composite van partition provides unmatched protection with lightweight material. Built from thermoformed ABS and polycarbonate and is engineered to resist maximum impact. With a snug fit and rattle free construction it gives you:

- Ergonomic cabin comfort
- 180 degree rear visibility
- Airtight climate control

More information on P.12

**THE PERFECT FIT**  
FOR YOUR TOUGHEST JOBS

**RANGER**<sup>TM</sup>  
DESIGN

*Our Promise: To Help You Work More Effectively by Providing Organized Storage Solutions.*

# Maximize Cargo Capacity & Vehicle Performance With Contractor Grade, Organized Storage Systems

When you want the perfect upfit solution for your work vehicle, turn to Ranger Design. Tested for toughness, Ranger's shelving and upfits will take whatever abuse you can dish out. Their unsurpassed craftsmanship, combined with ideal fit and finish, provide a quiet ride with no rattles.



## CUSTOMER SERVICE

cs@rangerdesign.com  
1-800-565-5321  
rangerdesign.com



**THE PERFECT FIT**  
FOR YOUR TOUGHEST JOBS

